



Fully Integrated BLDC Motor Control from the Signal Generation to the Full BLDC Motor Control Chain

1. Description

The purpose of this document is to explain the theory and application of Atmel®'s integrated BLDC driver solution. The worldwide demand for BLDC systems is increasing rapidly. To fulfill this need, Atmel provides a BLDC system with integrated output stages up to 1A. The system is suitable for “under the hood” applications with ambient temperatures up to 150°C. Various built-in protection features make it ideal for a variety of automotive applications containing small motors.

Figure 1-1. Fully Integrated BLDC Motor Control

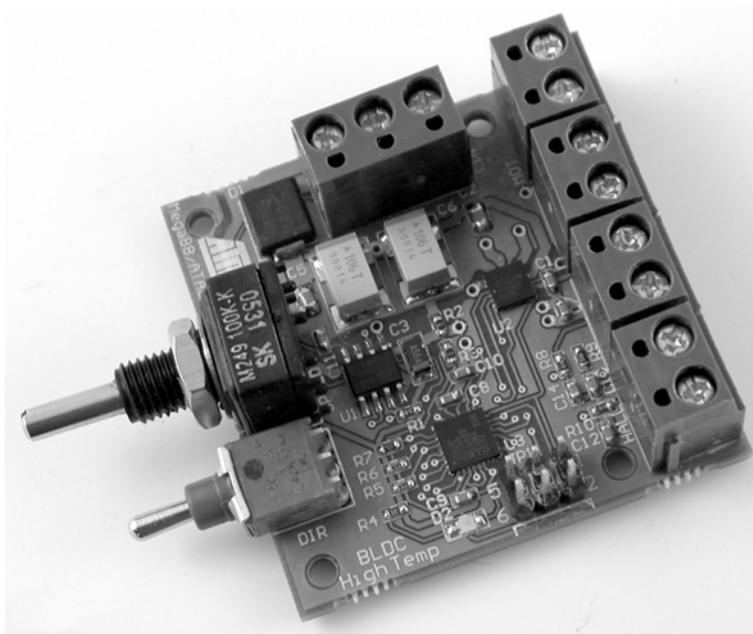

Fully Integrated
BLDC Motor
Control

Application Note



2. Fully Integrated BLDC System

Figure 2-1. Fully Integrated BLDC Motor Control Application

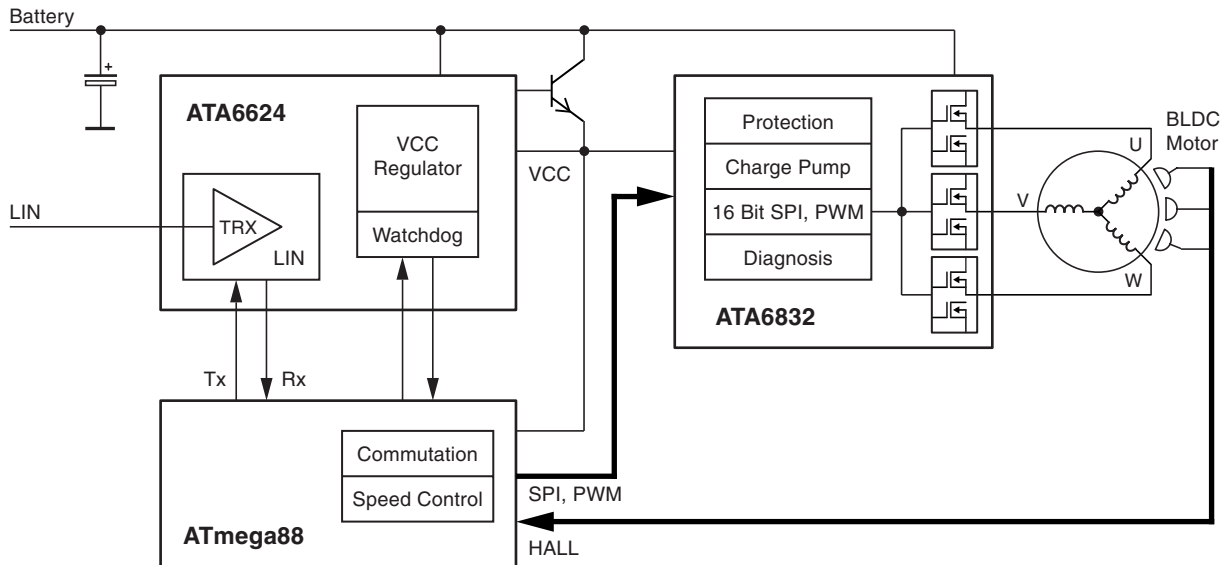

The system consists of three integrated circuits: Microcontroller ATmega88, Triple Half Bridge Driver ATA6832 and LIN System Basis Chip ATA6624 (Figure 2-1). The driver IC integrates three half bridges to run a BLDC motor directly.

The output drivers are fully protected. Open load, overtemperature, overload, and undervoltage will be reported to the microcontroller by SPI (Serial Peripheral Interface). The outputs will also be switched with the SPI interface. The direct PWM input is independent of the SPI and can be flexibly linked to the 6 output stages. This ensures an intelligent cruise control for various movement profiles adapted to the load.

The loop between motor movement and microcontroller is assured by hall sensors. The commutation is done by the microcontroller ATmega88. Furthermore, ATmega88's flash memory and computing capacity allow operation of LIN protocol 2.0.

The BLDC system is connected with the LIN transceiver ATA6624 to the automotive environment. Furthermore, this device generates the digital supply voltage.

No additional protection circuitry, e.g. current sensing is required due the enhanced in-circuit protection features for overload and overtemperature.

3. Theory of BLDC Operation

Brushless DC motors are used in a growing number of applications as they offer several advantages, including reduced noise, long lifetime (no brush erosion), reduced noise, good weight/size to power ratio, and hazardous operation environment usability (with flammable products).

These types of motor have a little rotor inertia compared with other motor types. Coils are attached to the stator, and commutation is controlled by electronics using position sensors feedback or back electromotive force measurements.

A BLDC motor stator basically includes three coils, which can be replicated to reduce torque ripple. In the same way, a rotor basically includes permanent magnets, composed of one to multiple pair of poles; this also affects step size (see [Figure 3-1](#)). Position can be estimated using three hall sensors, each spread at 120° around the stator.

Figure 3-1. Three-coil BLDC Motor, 1 and 2 Pair Poles



BLDC motor operation can be simplified by considering only three coils and one pair pole. The commutation of the phase depends on the position, in our case, the hall sensors value. When motor coils are supplied, a magnetic field is created and the rotor moves. The most elementary commutation driving method is an on-off scheme: a coil is either conducting or not. Only two coils are supplied at the same time; the third is floating. This is referred to as trapezoidal commutation or block commutation.

Figure 3-2. Power Stage

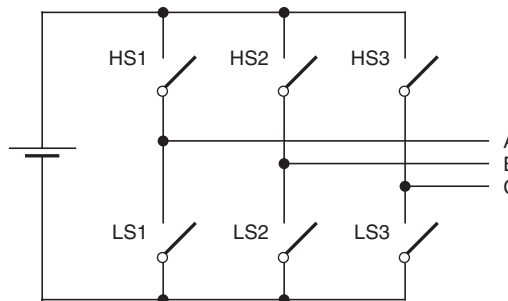
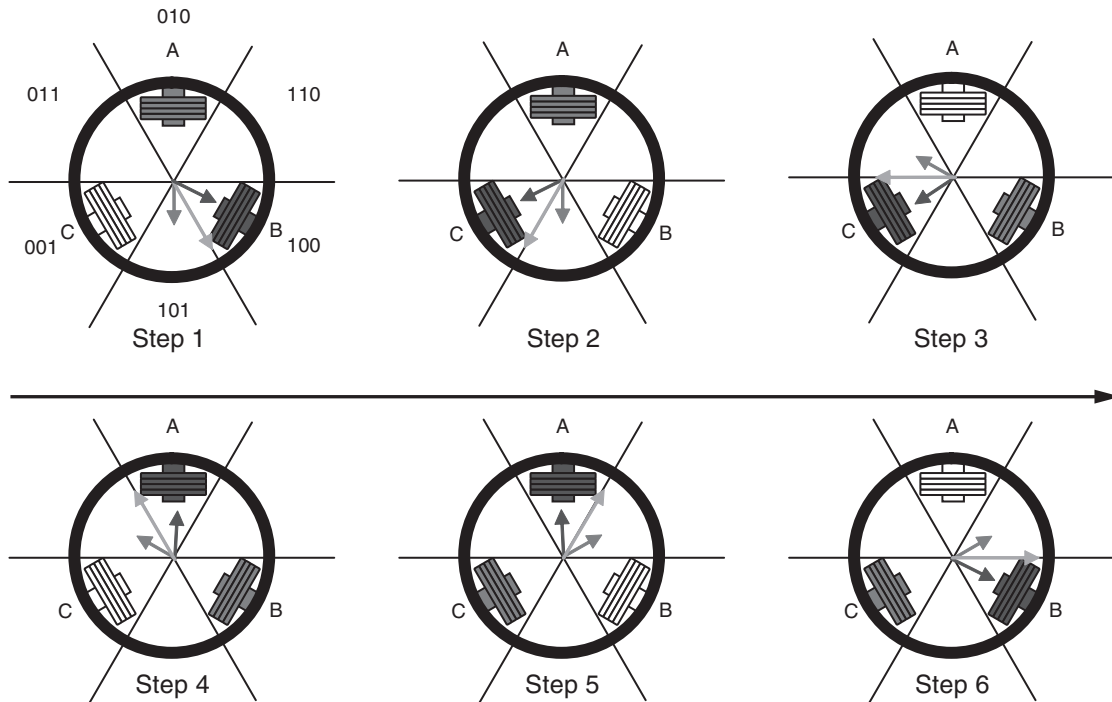

Figure 3-3. Commutation Steps for CW Operation



Reading the hall sensors value indicates commutation to be performed. For multiple pole motors, electrical rotation corresponds to mechanical rotation with the pair pole number factor.

Table 3-1. Switches Commutation for CW and CCW Rotation

Hall Sensors Value (CBA)	Switches Commutation for CW Rotation		Switches Commutation for CCW Rotation	
	Coils	Switches	Coils	Switches
101	A - B	HS1 - LS2	B - A	HS2 - LS1
001	A - C	HS1 - LS3	C - A	HS3 - LS1
011	B - C	HS2 - LS3	C - B	HS3 - LS2
010	B - A	HS2 - LS1	A - B	HS1 - LS2
110	C - A	HS3 - LS1	A - C	HS1 - LS3
100	C - B	HS3 - LS2	B - C	HS2 - LS3

Commutations are updated at each step to create a rotating magnetic field as shown in [Figure 3-3](#).

This method takes full advantage of the ATA6832 as commutations can be transmitted at each step, while PWM allows magnetic field magnitude tuning to act independently on motor torque and speed.

4. Driver ATA6832

The ATA6832 offers a variety of diagnostic and protection features including supervised low battery voltage, overload, open load, and temperature monitoring.

4.1 Maximum Speed

The commutation is done by microcontroller. The hall sensors are the input channel, which provide the motor position feedback. The SPI interface, which is the interface to the integrated triple half-bridge driver, is the output channel. The time schedule for commutation is shown in [Figure 6-1 on page 10](#).

The data transfer rate of the SPI is restricted; 2 MHz is the maximum transfer rate to the ATA6832. 16 bit plus communication control allows a maximum theoretical SPI rate of up to 100 kHz – one command every 10 μ s.

The maximum output switch speed of the ATA6832 is up to 25 kHz. Changing the output state is possible every 40 μ s.

A BLDC motor with a 3-pole stator and one double pole enables, with a defined control, the maximum speed. A rotor with two double poles enables half the speed. A single double-pole motor in one rotation passes through 6 different switching states of the three output half bridges (refer to [Table 3-1 on page 4](#)). Each switching state is controlled by one SPI command; therefore, six SPI commands are required for one turn.

An output switch rate of 40 μ s and 6 times each turn results in a minimum of 240 μ s for one rotation.

4.2 Open BLDC Load Detection

To detect the open load, there are integrated current sources on each output stage. Turning off open-load detection bit (OLD set to low), the current sources are switched on. The low side test current is guaranteed by design to be higher than high side test current. Therefore, if no load is connected to an output, all the three low-side switches will report open load by turning their output register bit on.

If one output is switched to high and the BLDC motor is connected correctly, both neighboring outputs will show high-side open load. In the event of open load on one string, this output will signal low-side open load.

Under normal operation, the open load current sources should be switched off by setting OLD bit to high. Otherwise, this circuitry will produce power dissipation.

4.3 Switching PWM

To control the outputs with PWM, there is one PWM input pin available for all six outputs. The outputs to operate with PWM can be selected by activating the corresponding bit of the six input data registers PLx/PHx. If PWM operation mode is activated for an output by these input bits, its input data register switch HSx/LSx is “and-connected” with the input pin PWM. The selected outputs follow the PWM input signal.

For cruise control, e.g., to start or stop a BLDC motor, PWM is necessary. To control the speed, only one dedicated PWM for all three BLDC motor strings is required. Controlling the current through the strings, it is sufficient to switch only one output of a half bridge, either high side or low side. This circumstance enables running of the BLDC driver with only one PWM frequency. Only one microcontroller timer is necessary.

The high-side switches of the ATA6831 and ATA6832 are faster than the low-side switches. PWM frequency up to 25 kHz is possible using the high-side switches.

4.4 Cooling Area Design

The drivers IC ATA6831/ATA6832 are housed in a special QFN package. QFN package is particularly suitable for power package because of the exposed die pad. To make use of this advantage, it has to be assured the head slug is completely soldered to the PCB.

To reduce thermal resistance, vias are required down to the soldering layer. A sufficing ground plane has to be placed on the soldering layer to eliminate the thermal energy.

A via diameter of 0.3 mm to 0.4 mm and a spacing of 1 mm to 1.5 mm has proven to be most suitable. Some care should be taken of the copper area's planarity, in particular, any solder bumps arising at the thermal vias should be avoided.

To minimize package size down to 4 mm × 4 mm, pins are only on three sides of the package.

5. The Application Board

The application board is run capable when connected to 12V at connector LIN (see [Figure 5-1 on page 8](#)). The board can be connected to the automotive environment over a LIN bus by a LIN clamp; however, there is no LIN protocol implemented in the microcontroller. The ATA6625 on this application board is used to generate a 5V digital supply.

A switch (DIR) for run/stop, clockwise, counterclockwise, and a potentiometer (SPEED) for variable speed (PWM) input are available on the board for stand-alone prototyping.

The feedback loop from BLDC motor to microcontroller ATmega88 is done by hall sensors. The three hall inputs can be linked to the connector HALL as well as the 5V supply for the hall sensors

5.1 On-board Features

The application board provides the following features:

- ATmega88 QFN32
 - MCU
- ATA6832 QFN
 - Integrated triple half bridges to drive BLDC motor and check its operations
- ATA6625 SO8
 - 1 x LIN interface 1.3 and 2.0 compliant
 - 5V power supply regulator
 - Up to 125°C (Using an ATA6624 with an external transistor would allow up to 150°C operation)
- On-Off-On switch
 - Stand-alone commands interface: Run/stop, clockwise, and counterclockwise.
- Potentiometer
 - Stand-alone speed variation command (PWM ratio)
- System clock
 - Internal RC oscillator
- Connectors
 - Power supply (battery voltage) and LIN
 - BLDC Motor connector (3 phase)
 - Hall sensor inputs and supply (3 filtered inputs and 5V regulated supply voltage)
 - ISP/debugWire connector, for on-chip in-situ Programming (ISP) and for on-chip debugging using JTAG ICE supported by AVR Studio® interface⁽¹⁾
- Dimensions: 45 mm × 45 mm

Note: 1. The ATmega88 is supported by AVR Studio, version 4.12 or higher. For up-to-date information on this and other AVR® tool products, please consult our web site. The newest version of AVR Studio, AVR tools and this user guide can be found in the AVR section of the Atmel web site, <http://www.atmel.com>

Figure 5-1. Application Board Top View and Connector Usage

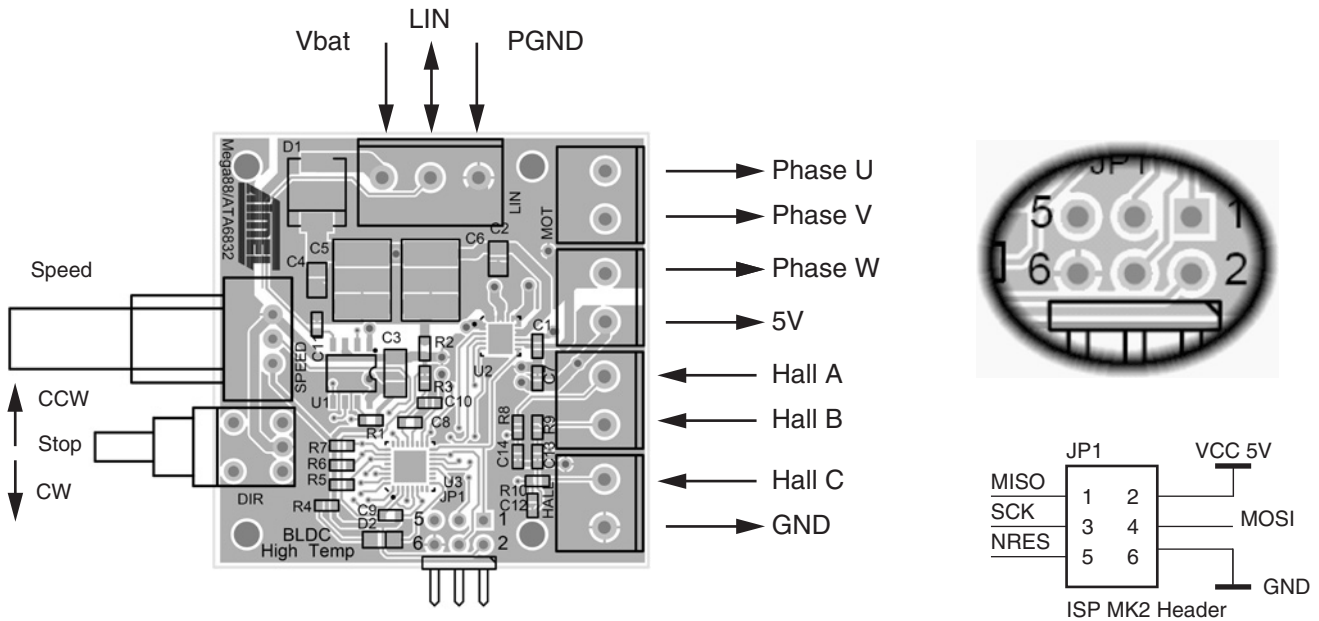

5.2 High Ambient Temperature

The BLDC system is designed for high temperature environments. The MCU ATmega88 and the driver ATA6832 are qualified up to an ambient temperature of 150°C. The ATA6832 has enhanced temperature management; each of its output stages contains a thermal sensor. In addition to the thermal shutdown function, a thermal prewarning function is available. If the temperature exceeds the prewarning threshold, the microcontroller can react by reducing output power.

The SBC (system basis chip) ATA6625 is only qualified for junction temperatures up to 150°C. The power dissipation of its voltage regulator only allows for ambient temperature up to 125°C. ATA6624, a member of the same SBC family, allows operation with a discrete transistor for line regulation. Transistors are available for junction temperatures higher than 150°C. If such a line regulation transistor dissipates the heat, ATA6624's temperature rise is only 3°C. Its possible ambient temperature is 147°C. Using a high temperature voltage regulator instead of Atmel's SBC enables a full 150°C temperature range.

All discrete components used are enabled for temperatures up to 150°C.

Mounted connectors, a switch, and a potentiometer on the board, enable prototyping; however, these components are not high temperature qualified. The board can be integrated in hot temperature environment by wires.

6. Software Description

All code is implemented in C language, except SPI interrupt subroutine, which is implemented in assembly. Source code can be compiled using IAR® EWAVR 4.20A as well as AVR-GCC (WinAVR-20060421 with AVR Studio).

HTML documentation is included in the package. Use the High_temp_BLDC.html file in the root directory to start viewing the documentation.

Software behavior can be dispatched in three main working modes:

- Motor stopped
 - In this mode, no hall sensors interrupts occurs. To maintain ATA6832 diagnostics, SPI communication is constantly performed by main loop.
 - Command switch enables starting of the motor. A first frame has to be sent to the power driver to start the motor. This frame shall contain commutations to be applied according to motor position (hall sensors inputs) and to desired direction.
 - While stopped, ATA6832 is switched into standby mode to decrease current consumption to lower than 20 μ A.
- Motor running
 - Once the motor is started, SPI communications (commutations), are only handled by hall sensors ISR, each time an interrupt occurs.
 - Command switch can be used to break the commutations evolution, and thus stop the motor.
- Degraded mode: two possibilities
 - Motor has been stopped because of an overload, an over temperature, etc. Software waits for the user to clear the fault (operate switch to stop position).
 - Motor is still running (software behavior is similar to the motor running mode). User is informed that a fault has been detected (over temperature, one or more switches are secured, etc.). Software can reduce output power and waits for a user order to clear the fault (operate switch to stop position).

6.1 Resources

Table 6-1. Code, Data, and CPU Resources (Without Compiler Optimizations)

Compiler/Resources	Code Size (Flash)	Data Size (Ram)	CPU Load
IAR EWAVR 4.20A	1 304 bytes	367 bytes	See §Schedule
AVR-GCC	1 826 bytes	48 bytes	

The following MCU peripherals are used:

- SPI
 - Commutation data and status data transfer to/from ATA6832 power driver
- Timer 1
 - PWM generation through Output Compare 1A (OC1A pin)
- ADC channel 0
 - Speed potentiometer value acquisition (Acts on PWM ratio)

- Pin change interrupts
 - Hall sensor edges detection are used to detect motor position evolution
- I/O
 - LED, Switch operations
- Optional (not managed by this stand-alone software)
 - UART and Input Capture for LIN implementation

6.2 Schedule

Figure 6-1. Software Schedule

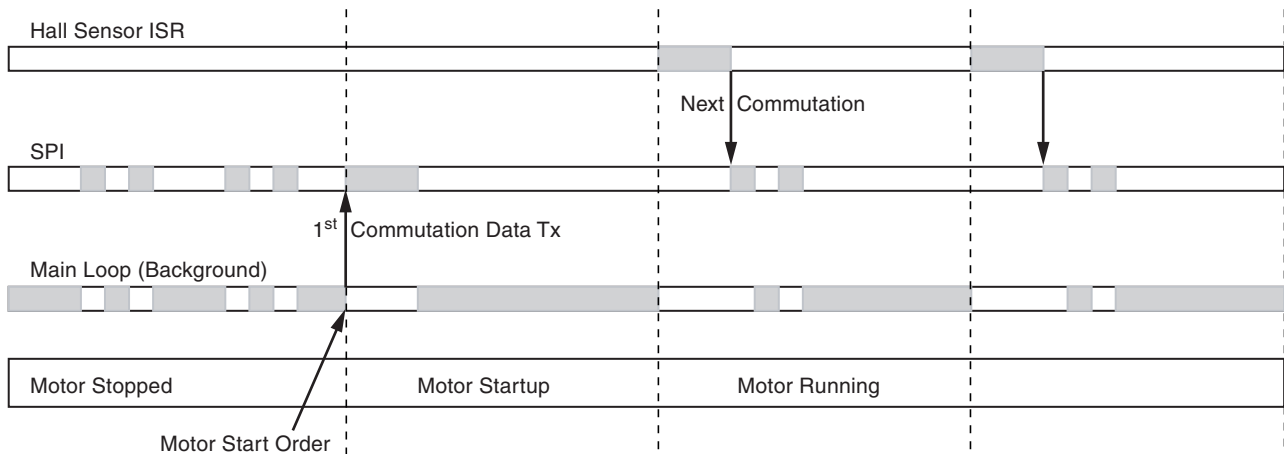

CPU load while motor is running

- Using IAR EWAVR 4.20A

The main loop is continually executed in background. It could be scheduled. Main loop measured time cycle is 21 μ s.

For each output commutation, one hall interrupt and two SPI interrupts occur. This makes for one commutation:

$$\text{CPU time} = \text{Hall ISR time} + \text{Both SPI ISR time} = 8.4 \mu\text{s} + 4.8 \mu\text{s} = 13.2 \mu\text{s}/\text{commutation}.$$

- Using AVR-GCC

The main loop is continually executed in background. It could be scheduled. The main loop measured time cycle is 30 μ s.

For each output commutation, one hall interrupt and two SPI interrupts occur. This makes for one commutation:

$$\text{CPU time} = \text{Hall ISR time} + \text{Both SPI ISR time} = 16 \mu\text{s} + 4.8 \mu\text{s} = 20.8 \mu\text{s} / \text{commutation}.$$

The main loop is not taken into account for CPU load computation below, as it is not scheduled and executed in background. Assuming we have 6 interrupts for a complete motor rotation and a 4-pair pole motor, we can determine the following CPU load versus rotation speed.

Figure 6-2. CPU Load versus Speed for an 8 Pole Motor

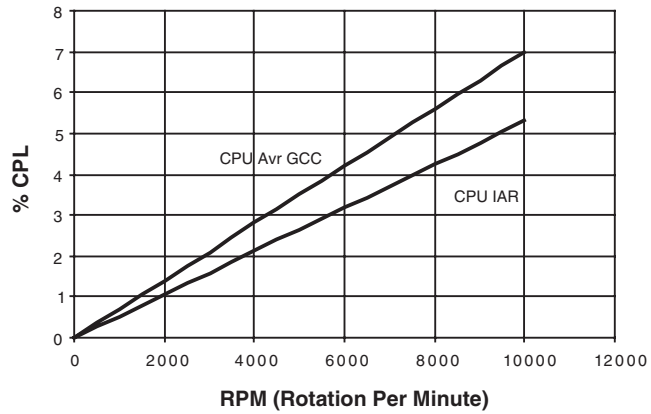

6.3 Diagrams

Figure 6-3. Flowchart for Hall Sensors ISR

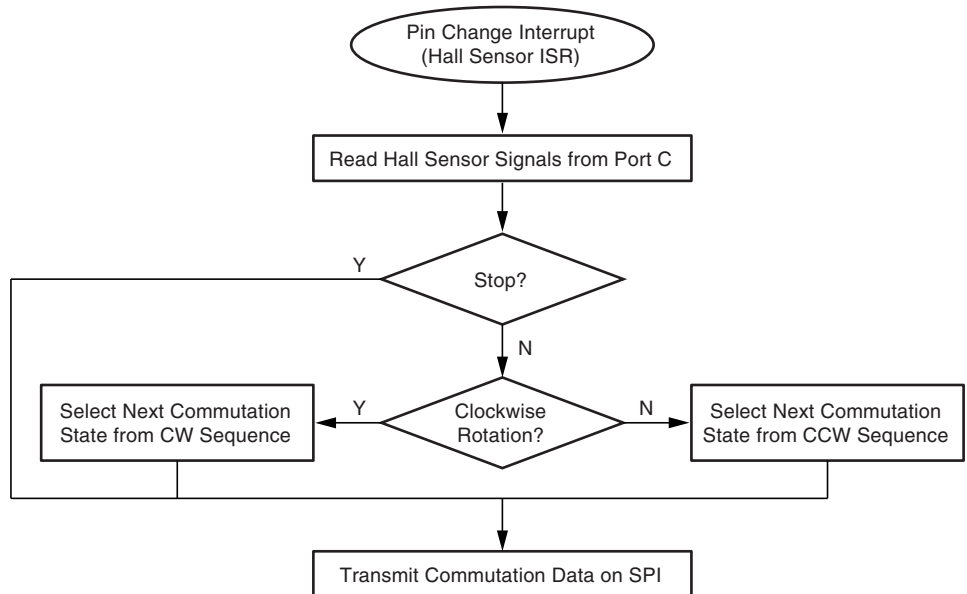

Figure 6-4. Flowchart for SPI Transfer Completed ISR

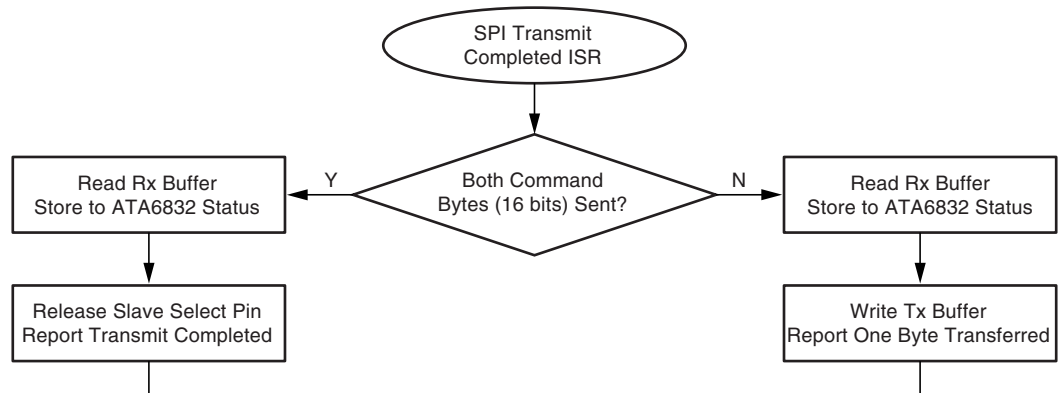
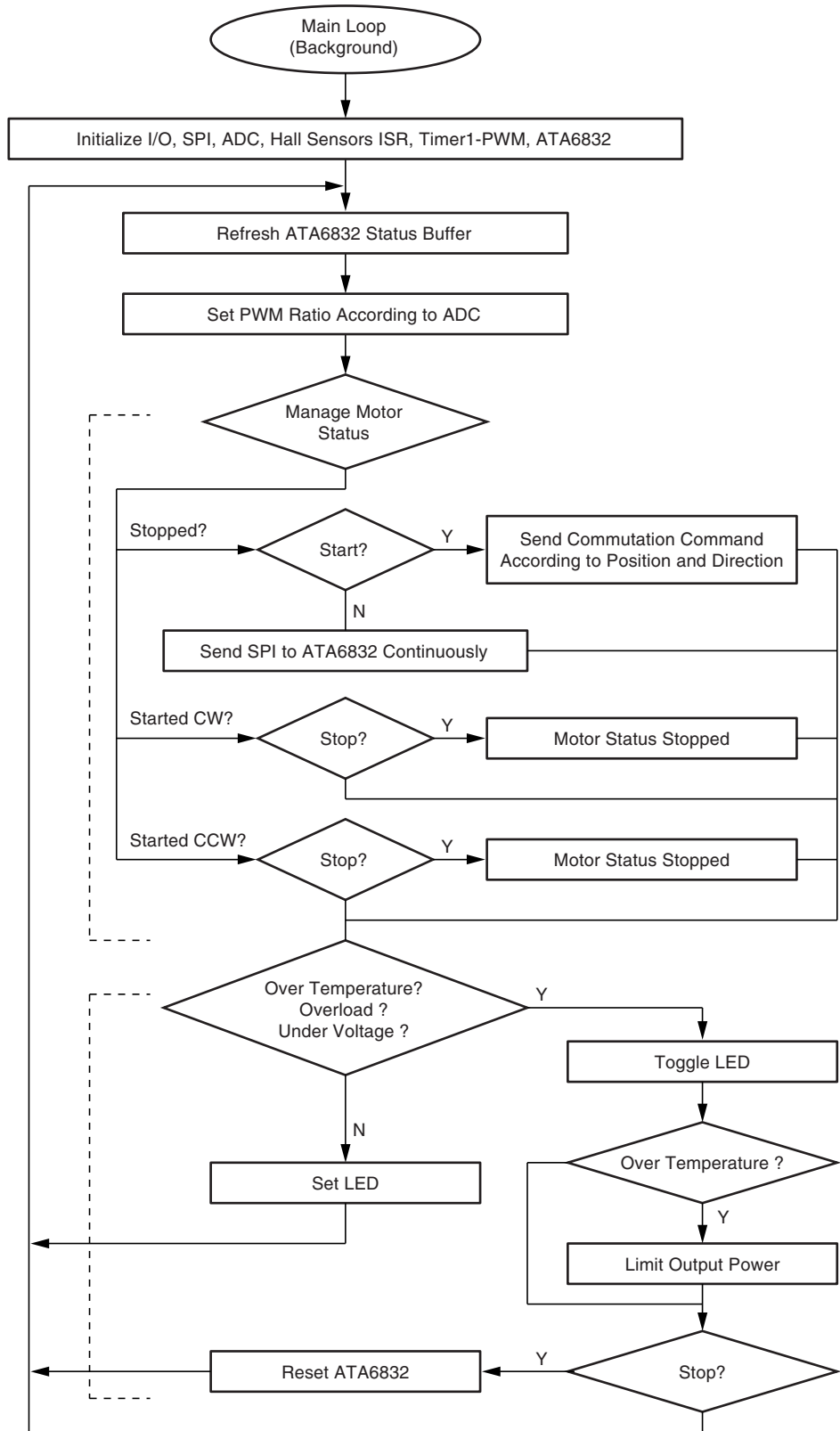

Figure 6-5. Main Loop Flowchart



6.4 Modules

```
void SPI_MasterInit(void)
```

Initializes SPI used to access ATA6832, configures I/O, 2MHz frequency, data sample at clock falling edge, LSB first.

```
SPI_status_t SPI_transmit_16(unsigned int data_16)
```

Sends 16 bit data on SPI (using interrupts), depending on returned SPI status. Returns SPI_Initiate_tx status if successful.

```
SPI_status_t SPI_get_Rx_data(unsigned int *data_16_ptr)
```

Puts the SPI received data into pointed buffer when data has been received. In that case it returns SPI_Completed status and changes SPI status to ready.

```
void ADC_Init(void)
```

Sets up ADC to acquire desired speed from potentiometer.

```
unsigned int get_speed()
```

Returns last acquired desired speed from potentiometer. Checks ADC end conversion flag to start new conversions and update latest desired speed.

```
void Hall_sensors_ISR_init(void)
```

Sets up pin change interrupts on hall sensor inputs.

```
Motor_ctrl_t BLDC_start(unsigned char direction)
```

Sends first commutation order to start motor according to desired direction and to hall sensors inputs. Returns started status when SPI frame has been emitted.

```
void Timer1_start(void)
```

Configures timer 1 for PWM on Output compare 1 A.

```
void manage_time_base(void)
```

Manages a general purpose time base (for LED toggling, etc.).

```
TIMER1_SET_OC1A_PWM(val)
```

Changes PWM ratio (macro).

7. Application Board Full Description

Figure 7-1. BLDC Application Board Schematic

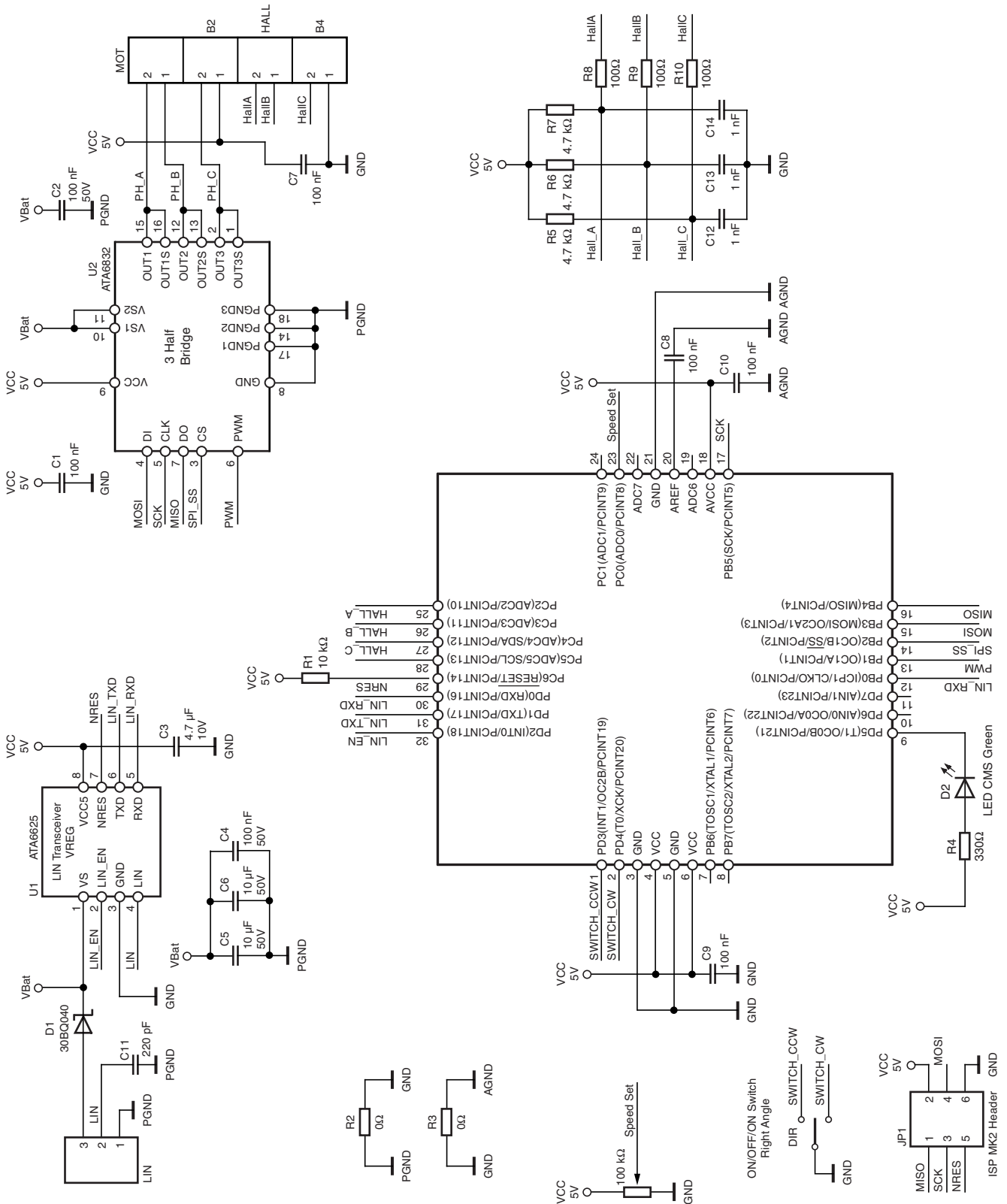

Figure 7-2. BLDC Application Board Top View and Component Placement

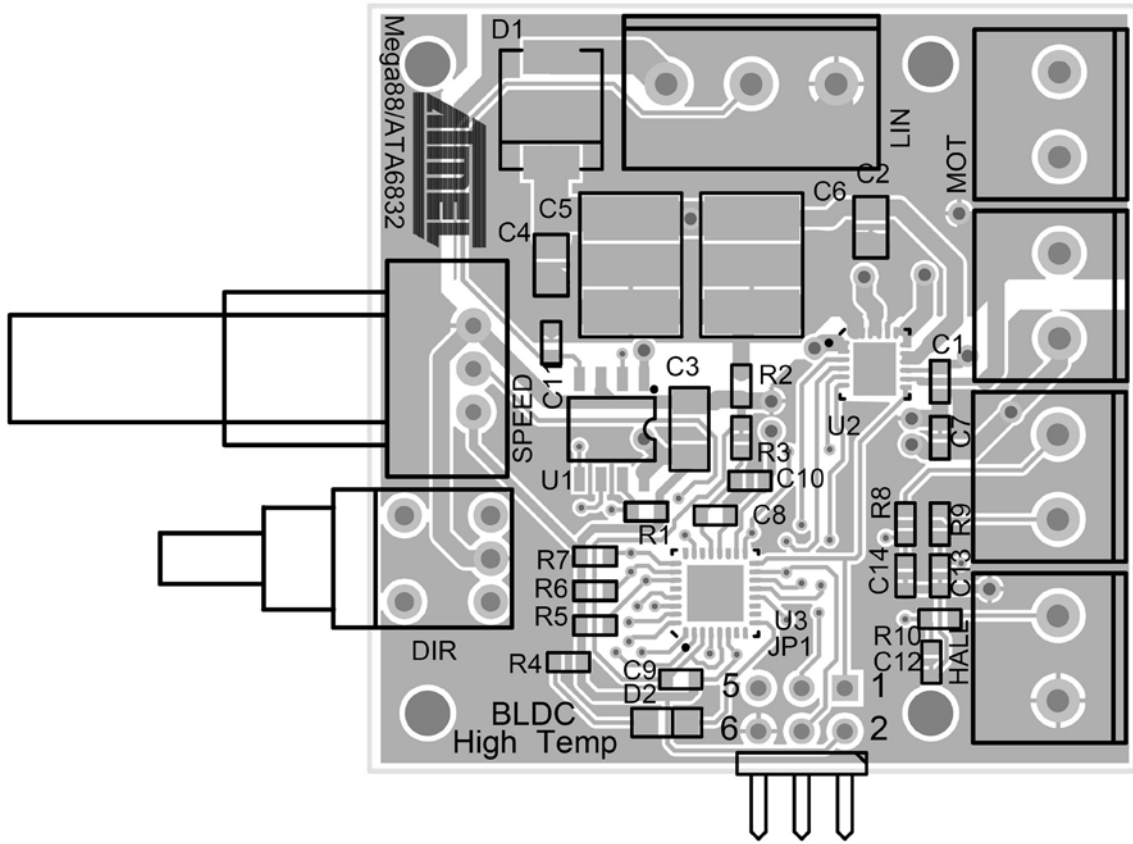

Figure 7-3. BLDC Application Board Bottom View

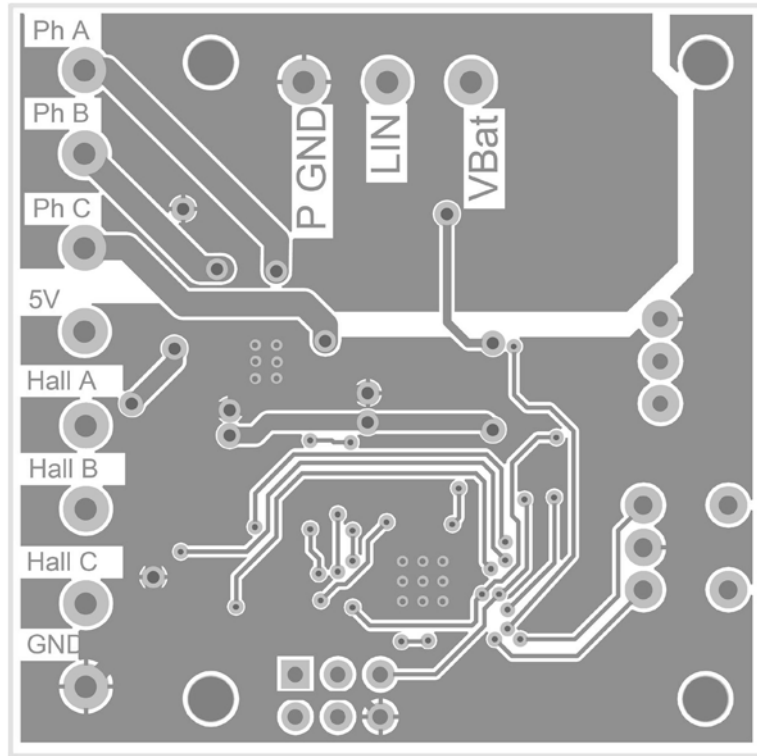

Table 7-1. BLDC Application Board Connectors

Connector	Clamp	Function	Direction
LIN	1	Power Ground	Input
	2	LIN input	Input
	3	Power 12V	Input
MOT	1	Motor Phase A	Output
	2	Motor Phase B	Output
B2	1	Motor Phase C	Output
	2	Power 5V	Output
HALL	1	Hall A	Input
	2	Hall B	Input
B4	1	Hall C	Input
	2	Power GND	Output



Atmel Corporation

2325 Orchard Parkway
San Jose, CA 95131, USA
Tel: 1(408) 441-0311
Fax: 1(408) 487-2600

Regional Headquarters

Europe

Atmel Sarl
Route des Arsenaux 41
Case Postale 80
CH-1705 Fribourg
Switzerland
Tel: (41) 26-426-5555
Fax: (41) 26-426-5500

Asia

Room 1219
Chinachem Golden Plaza
77 Mody Road Tsimshatsui
East Kowloon
Hong Kong
Tel: (852) 2721-9778
Fax: (852) 2722-1369

Japan

9F, Tonetsu Shinkawa Bldg.
1-24-8 Shinkawa
Chuo-ku, Tokyo 104-0033
Japan
Tel: (81) 3-3523-3551
Fax: (81) 3-3523-7581

Atmel Operations

Memory

2325 Orchard Parkway
San Jose, CA 95131, USA
Tel: 1(408) 441-0311
Fax: 1(408) 436-4314

Microcontrollers

2325 Orchard Parkway
San Jose, CA 95131, USA
Tel: 1(408) 441-0311
Fax: 1(408) 436-4314

La Chantrerie
BP 70602
44306 Nantes Cedex 3, France
Tel: (33) 2-40-18-18-18
Fax: (33) 2-40-18-19-60

ASIC/ASSP/Smart Cards

Zone Industrielle
13106 Rousset Cedex, France
Tel: (33) 4-42-53-60-00
Fax: (33) 4-42-53-60-01

1150 East Cheyenne Mtn. Blvd.
Colorado Springs, CO 80906, USA
Tel: 1(719) 576-3300
Fax: 1(719) 540-1759

Scottish Enterprise Technology Park
Maxwell Building
East Kilbride G75 0QR, Scotland
Tel: (44) 1355-803-000
Fax: (44) 1355-242-743

RF/Automotive

Theresienstrasse 2
Postfach 3535
74025 Heilbronn, Germany
Tel: (49) 71-31-67-0
Fax: (49) 71-31-67-2340

1150 East Cheyenne Mtn. Blvd.
Colorado Springs, CO 80906, USA
Tel: 1(719) 576-3300
Fax: 1(719) 540-1759

Biometrics

Avenue de Rochepleine
BP 123
38521 Saint-Egreve Cedex, France
Tel: (33) 4-76-58-47-50
Fax: (33) 4-76-58-47-60

Literature Requests

www.atmel.com/literature

Disclaimer: The information in this document is provided in connection with Atmel products. No license, express or implied, by estoppel or otherwise, to any intellectual property right is granted by this document or in connection with the sale of Atmel products. **EXCEPT AS SET FORTH IN ATMEL'S TERMS AND CONDITIONS OF SALE LOCATED ON ATMEL'S WEB SITE, ATMEL ASSUMES NO LIABILITY WHATSOEVER AND DISCLAIMS ANY EXPRESS, IMPLIED OR STATUTORY WARRANTY RELATING TO ITS PRODUCTS INCLUDING, BUT NOT LIMITED TO, THE IMPLIED WARRANTY OF MERCHANTABILITY, FITNESS FOR A PARTICULAR PURPOSE, OR NON-INFRINGEMENT. IN NO EVENT SHALL ATMEL BE LIABLE FOR ANY DIRECT, INDIRECT, CONSEQUENTIAL, PUNITIVE, SPECIAL OR INCIDENTAL DAMAGES (INCLUDING, WITHOUT LIMITATION, DAMAGES FOR LOSS OF PROFITS, BUSINESS INTERRUPTION, OR LOSS OF INFORMATION) ARISING OUT OF THE USE OR INABILITY TO USE THIS DOCUMENT, EVEN IF ATMEL HAS BEEN ADVISED OF THE POSSIBILITY OF SUCH DAMAGES.** Atmel makes no representations or warranties with respect to the accuracy or completeness of the contents of this document and reserves the right to make changes to specifications and product descriptions at any time without notice. Atmel does not make any commitment to update the information contained herein. Unless specifically provided otherwise, Atmel products are not suitable for, and shall not be used in, automotive applications. Atmel's products are not intended, authorized, or warranted for use as components in applications intended to support or sustain life.

© 2007 Atmel Corporation. All rights reserved. Atmel®, logo and combinations thereof, Everywhere You Are®, AVR®, AVR Studio® and others, are registered trademarks or trademarks of Atmel Corporation or its subsidiaries. Other terms and product names may be trademarks of others.